

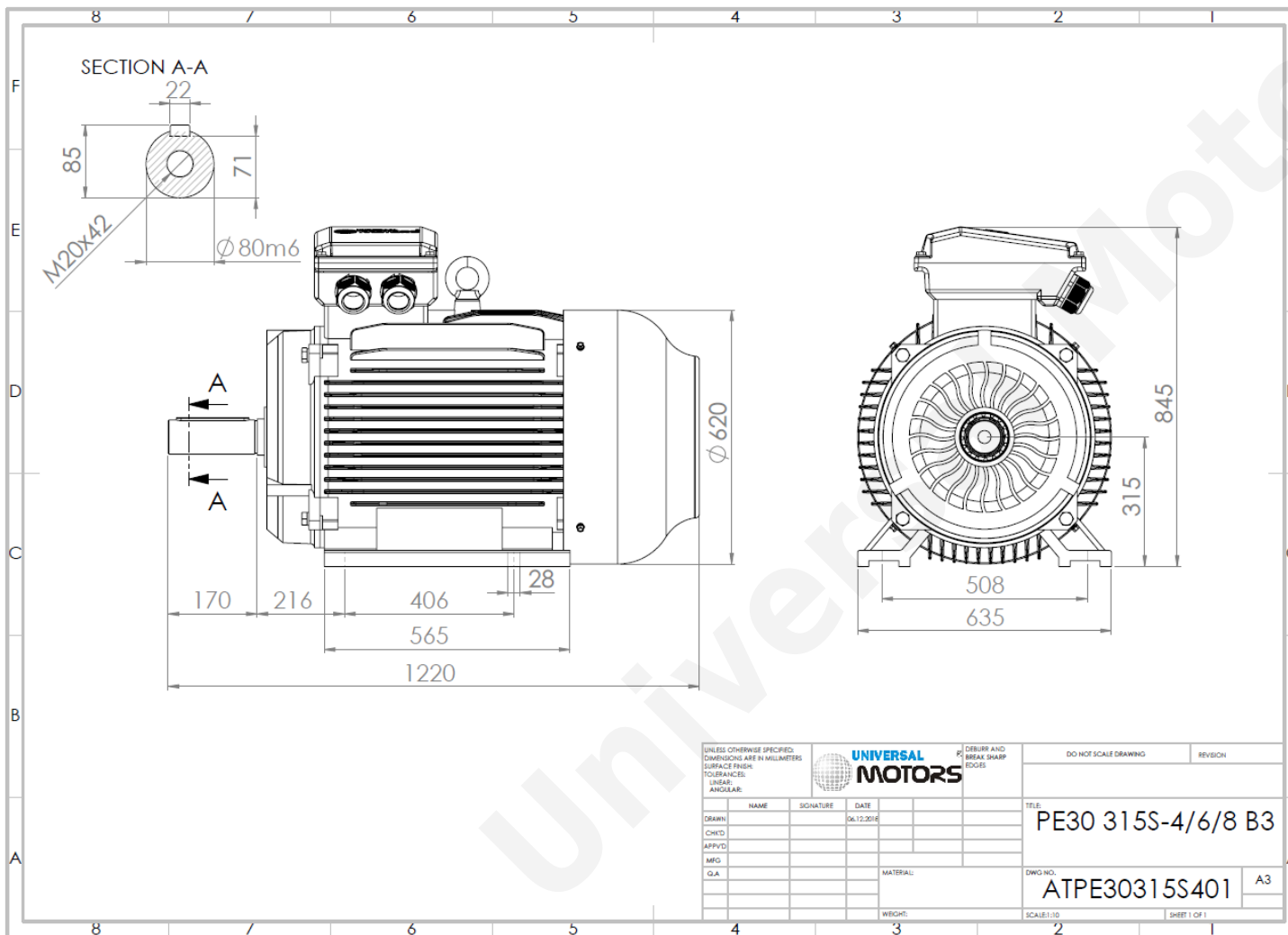

TECHNICAL DATA

Three Phase Electric Motors - Cast Iron Frame
 PE30 315 S 6 IE3
 75 kW / 100 Cv
 990 RPM



Motor type:	PE30 315 S 6 IE3
Output:	75 kW / 100 Cv
Speed (min ⁻¹):	990 RPM
Frequency:	50 Hz
Voltage:	400 V
Current:	136 A
Power factor (Cos Ø):	0.84
Poles:	6
Insulation class:	F
Temperature rise Class:	B
Efficiency 50%:	93.4 %
Efficiency 75%:	94.6 %
Efficiency 100%:	94.7 %
Torque:	723 N.m
Tstarting/Tnominal:	2.0
Istarting/Inominal:	6.6
Tmaximum/Tnominal:	2.0
Noise:	72 Db(A)
Weight:	791 Kg
Bearing DE:	NU 319
Bearing NDE:	6319 C3

Regime - S1

Altitude - 1000m

Environment Temperature - 40°C

CONTACTS:

UNIVERSAL MOTORS Tel: +351 252 299 080
 Rua de São Brás,745 Fax: +351 252 299 089
 4480-782 VILA DO CONDE Mail: geral@universalmotors.pt

* References applied only in the UK